



# OWNER'S MANUAL

## SLI 2.2 - SLI 4.2

CONNECTION



[connection.eu](http://connection.eu)



## WARNING

- Before you start your installation, make sure you carefully read and understand all instructions. Disregarding them might cause accidental harms or damage your devices.
- The vehicle electric system must have 12 VDC voltage with negative to ground. Make sure your car has it in order to avoid any damages to your amplifier and to the vehicle.
- Install the device in the vehicle parts where temperature is between 0° C (32° F) and 55° C (131° F).
- Make sure the location you chose for the components does not affect the correct functioning of the vehicle mechanical and electric devices.
- Do not run the cables or install the device next to electronic gearcases.
- Always wear protective eyewear when using tools that may generate splinters.
- When installation is over, and before plugging the main power supply fuse, check the system wiring and make sure all connections were done in the right way.
- Safety must be at the first place while driving. Listening volume must never cover noise coming from the outside and from the vehicle, in order for you to be able to promptly face emergency situation.
- Always insulate the connection between the SLI and the OEM headunit / OEM amplifier to avoid damage them.
- Always insulate the connection between the SLI and the +12V power supply system (battery).
- Always fuse +12 V SLI cable (RED) with 1A fuse to avoid any damage to the vehicle electrical system and or event of fire.

Elettromedia will not be liable for the direct or indirect damages due to a wrong use or a wrong connection of the device.

## PACKAGING CONTENTS

SLI 2.2

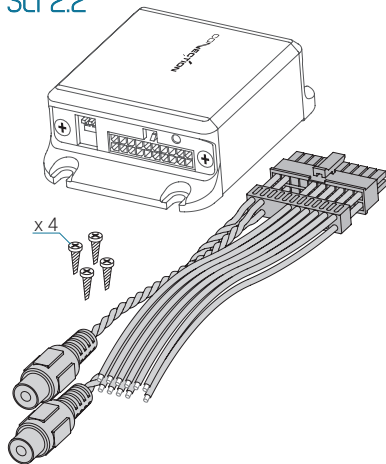

SLI 4.2

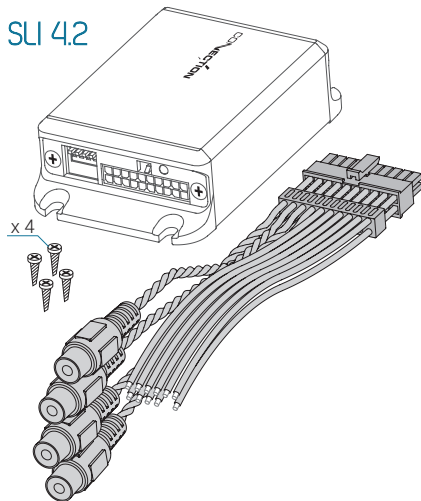

## INSTALLATION - FIXING - SIZE

SLI 2.2 - SLI 4.2

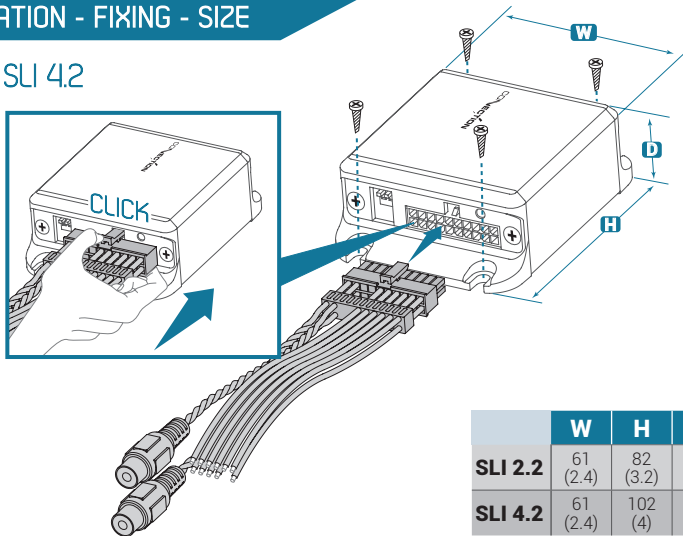

	W	H	D	
<b>SLI 2.2</b>	61 (2.4)	82 (3.2)	28 (1.1)	mm (in.)
<b>SLI 4.2</b>	61 (2.4)	102 (4)	28 (1.1)	mm (in.)

## CONNECTIONS

### SLI 2.2



**UNIVERSAL SPEAKERS  
SIMULATOR** circuit, simulates  
the load of the OEM speakers  
on the 4 Front + Rear input  
channels, for a complete  
compatibility with OEM  
Headunit / OEM Amplifier.

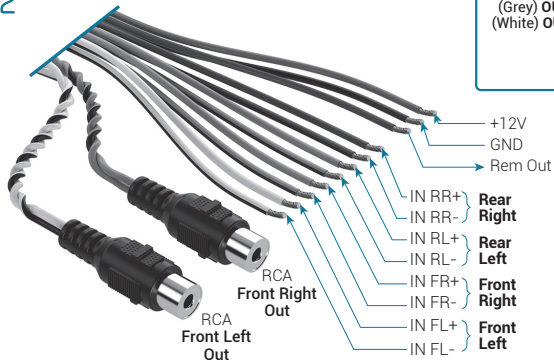

#### SLI 2.2 CABLE OUTPUT VIEW

(Red) +12V	●	GND (Black)
(Blue) REM OUT	□	NC
(Purple) IN RR+	●	IN RR- (Purple/Black)
(Green) IN RL+	●	IN RL- (Green/Black)
(Grey) IN FR+	●	IN FR- (Grey/Black)
(White) IN FL+	●	IN FL- (White/Black)
NC	□	NC
NC	□	NC
(Grey) OUT FR+	□	OUT FR- (Grey/Black)
(White) OUT FL+	□	OUT FL- (White/Black)

**RCA  
OUT**

\*Due to the presence of the USS circuit, please make sure to connect the high level cables to the RL and RR inputs only if they are disconnected from the OEM rear speakers.

# CONNECTIONS

## SLI 4.2



**UNIVERSAL SPEAKERS  
SIMULATOR** circuit, simulates  
the load of the OEM speakers  
on the 4 Front + Rear input  
channels, for a complete  
compatibility with OEM  
Headunit / OEM Amplifier.

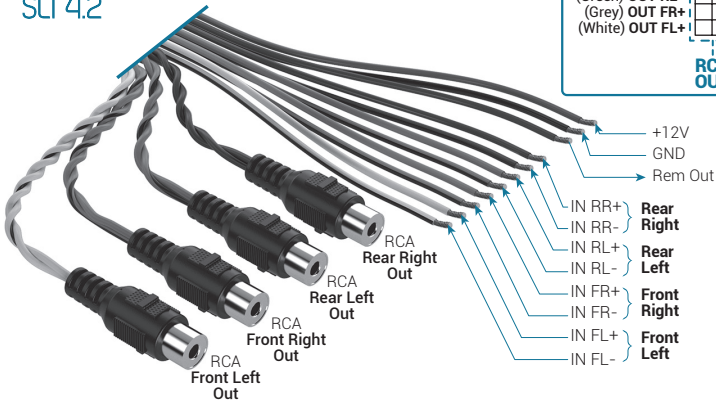

### SLI 4.2 CABLE OUTPUT VIEW

(Red) +12V	●	●	GND (Black)
(Blue) REM OUT	●	□	NC
(Purple) IN RR+	●	●	IN RR- (Purple/Black)
(Green) IN RL+	●	●	IN RL- (Green/Black)
(Grey) IN FR+	●	●	IN FR- (Grey/Black)
(White) IN FL+	●	●	IN FL- (White/Black)
(Purple) OUT RR+	□	□	OUT RR- (Purple/Black)
(Green) OUT RL+	□	□	OUT RL- (Green/Black)
(Grey) OUT FR+	□	□	OUT FR- (Grey/Black)
(White) OUT FL+	□	□	OUT FL- (White/Black)

**RCA  
OUT**

## CONNECTIONS: SLI 2.2 with OEM Headunit (without ART™ function)

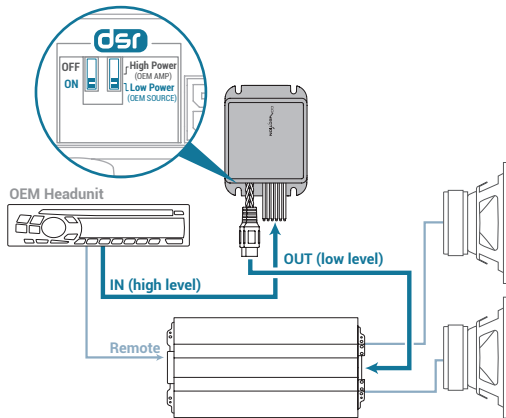

**DSR:** DOUBLE STEP-DOWN RATIO, allows correct level interfacing with OEM Headunit or OEM Amplifier by switch selection.



## CONNECTIONS: SLI 2.2 with OEM Headunit (with ART™ function)

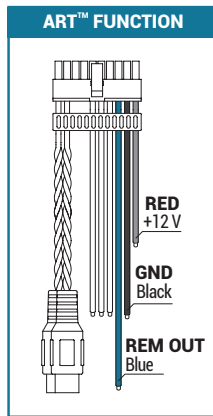
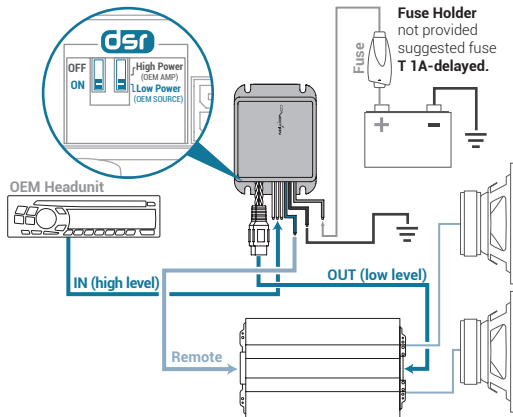

**DSR:** DOUBLE STEP-DOWN RATIO, allows correct level interfacing with OEM Headunit or OEM Amplifier by switch selection.

**ART™:** AUTOMATIC REMOTE TURN-ON/OFF function, generates a 12 V remote output when the OEM Headunit / Amplifier is turned ON/OFF (available only when SLI is powered).

## CONNECTIONS: SLI 4.2 with OEM Headunit (without ART™ function)

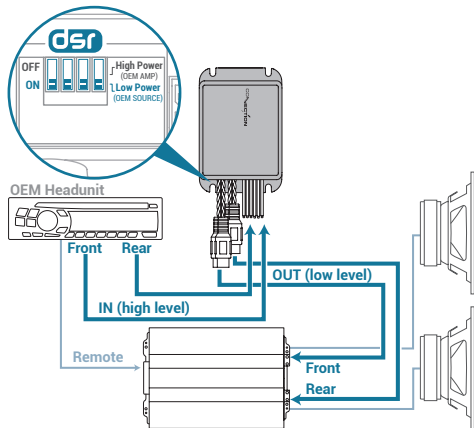

**DSR:** DOUBLE STEP-DOWN RATIO, allows correct level interfacing with OEM Headunit or OEM Amplifier by switch selection.

## CONNECTIONS: SLI 4.2 with OEM Headunit (with ART™ function)

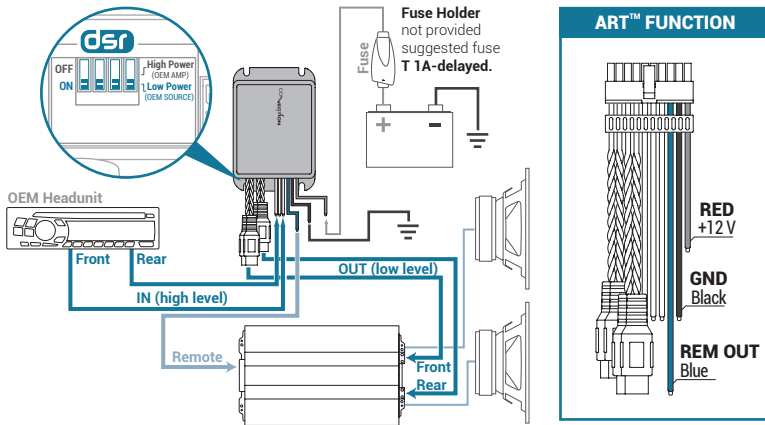

**DSR:** DOUBLE STEP-DOWN RATIO, allows correct level interfacing with OEM Headunit or OEM Amplifier by switch selection.

**ART™:** AUTOMATIC REMOTE TURN-ON/OFF function, generates a 12V remote output when the OEM Headunit / Amplifier is turned ON/OFF (available only when SLI is powered).

## CONNECTIONS: SLI 2.2 with OEM Amplifier (with ART™ function)

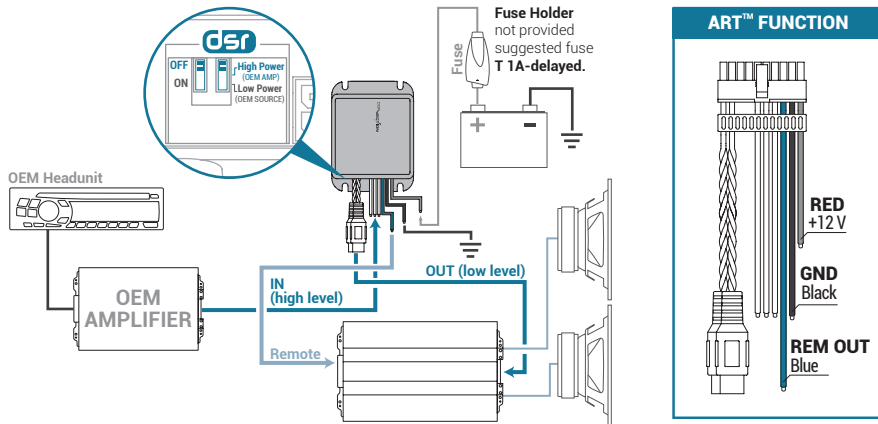

**DSR:** DOUBLE STEP-DOWN RATIO, allows correct level interfacing with OEM Headunit or OEM Amplifier by switch selection.

**ART™:** AUTOMATIC REMOTE TURN-ON/OFF function, generates a 12 V remote output when the OEM Headunit / Amplifier is turned ON/OFF (available only when SLI is powered).

## CONNECTIONS: SLI 4.2 with OEM Amplifier (with ART™ function)

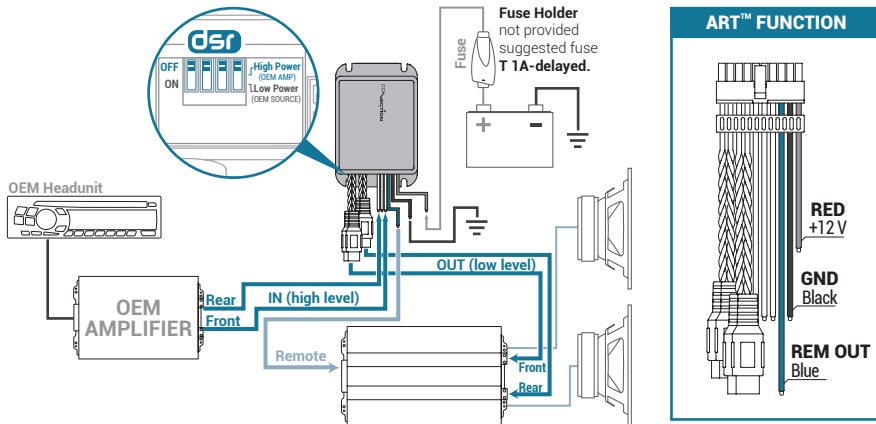

**DSR:** DOUBLE STEP-DOWN RATIO, allows correct level interfacing with OEM Headunit or OEM Amplifier by switch selection.

**ART™:** AUTOMATIC REMOTE TURN-ON/OFF function, generates a 12 V remote output when the OEM Headunit / Amplifier is turned ON/OFF (available only when SLI is powered).

## CONNECTIONS

### SLI 4.2 to stereo passive mixer

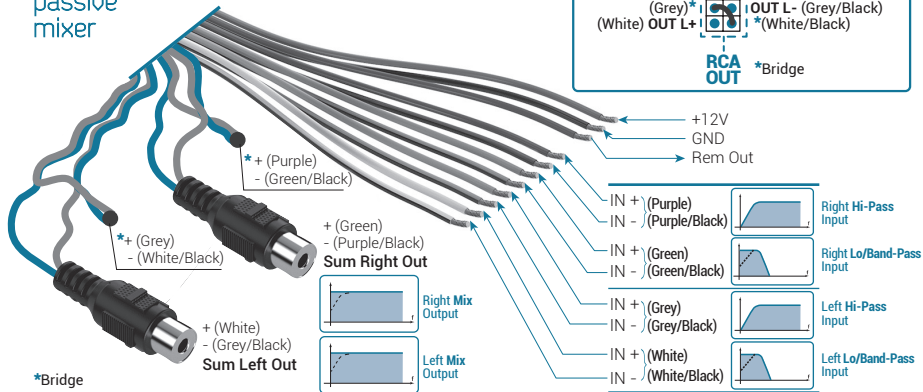

**UNIVERSAL SPEAKERS  
SIMULATOR** circuit, simulates  
the load of the OEM speakers  
on the Lo-Pass + Hi-Pass  
input channels, for a complete  
compatibility with OEM  
Headunit / OEM Amplifier.

#### SLI 4.2 CABLE OUTPUT VIEW

(Red) +12V	●	GND (Black)
(Blue) REM OUT	□	NC
(Purple) IN HI R+	●	IN HI R- (Purple/Black)
(Green) IN LO R+	●	IN LO R- (Green/Black)
(Grey) IN HI L+	●	IN HI L- (Grey/Black)
(White) IN LO L+	●	IN LO L- (White/Black)
(Purple)*	●	OUT R- (Purple/Black)
(Green)*	●	* (Green/Black)
(Grey)*	●	OUT L- (Grey/Black)
(White) OUT L+	●	* (White/Black)

**RCA OUT** \*Bridge

## CONNECTIONS: SLI 4.2 with Audison AP bit amplifier

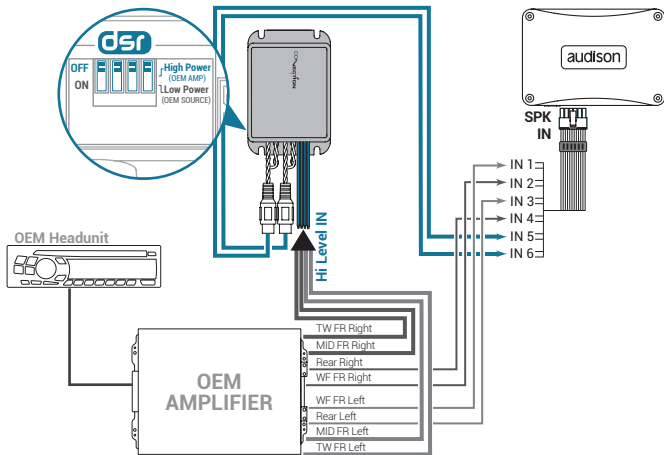

**DSR:** DOUBLE STEP-DOWN RATIO, allows correct level interfacing with OEM Headunit or OEM Amplifier by switch selection.

## CONNECTIONS: SLI 4.2 with Audison AP F8.9 bit amplifier

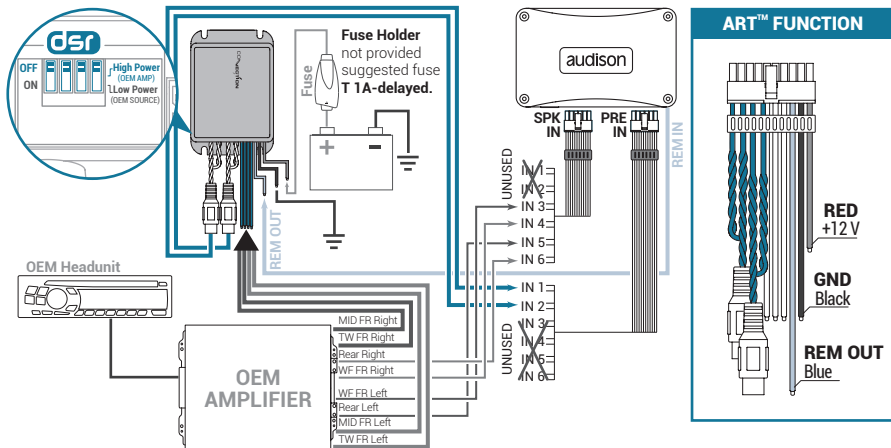

**DSR:** DOUBLE STEP-DOWN RATIO, allows correct level interfacing with OEM Headunit or OEM Amplifier by switch selection.

**ART™:** AUTOMATIC REMOTE TURN-ON/OFF function, generates a 12 V remote output when the OEM Headunit / Amplifier is turned ON/OFF (available only when SLI is powered).



## TECHNICAL SPECIFICATIONS

	SLI 2.2	SLI 4.2
<b>Input / Output Channels</b>	4*/2	4/4
<b>Maximum Input Power</b>	50W@4Ω (Lo-Power) / 150W@4Ω (Hi-Power)	
<b>Nominal Conversion Ratio</b>	4:1 Lo-Power / 8:1 Hi-Power	
<b>Input Impedance**</b>	200 Ω	
<b>Output Impedance</b>	400 Ω	
<b>Distortion (THD+N@25W rms input, Lo-Power)</b>	0,15% 100 Hz, 0,07% 1 kHz, 0,07% 10 kHz	
<b>Frequency Response (-3dB)</b>	15 ÷ 40 kHz	
<b>Remote Out*** (Only when LSI is Powered)</b>	12 VDC - 100mA max @ 13 VDC input	
<b>Weight (kg. / lb.) including cable</b>	0,16 (0.36)	0,25 (0.55)

\* Due to the presence of the USS circuit, please make sure to connect the high level cables to the RL and RR inputs only if they are disconnected from the OEM rear speakers.

\*\* Input impedance when the USS function is Off.

\*\*\* In countries where the legislation on electromagnetic compatibility is not mandatory under ECE / UN Regulation no. 10/5.

# Note

---

---

---

---

---

---

---

# Note

---

---

---

---

---

---

---



## WARRANTY

The products are guaranteed according to the laws in force.  
Possible damaged products must be sent back, with authorization, to CONNECTION dealer to be repaired or replaced.  
Products damaged by incorrect use/installation are not covered by warranty.

## INFO

In Italy: [supporto.tecnico@elettromedia.it](mailto:supporto.tecnico@elettromedia.it)  
Abroad: [support@elettromedia.it](mailto:support@elettromedia.it)